



SPECIFICATION SHEET

SPECIFICATION SHEET NO.	Q0721- ST05B473K500DC
DATE	July 21, 2023
REVISION	A2
DESCRIPTION	Multilayer Ceramic Chip Capacitors ST0805 (2012 Metric) Series, L2.00*W1.25*H1.25mm, Thickness: 1.35mm Max. Dielectric X7R, Capacitance 0.047μF, Tolerance ±10%, Rated Voltage 50V Operating Temp. Range -55°C ~+125°C Package in Tape/Reel, 3,000pcs/Reel RoHS/RoHS III compliant
CUSTOMER	
CUSTOMER PART NUMBER	
CROSS REF. PART NUMBER	
ORIGINAL PART NUMBER	Aillen ST05B473K500DC
PART CODE	ST05B473K500DC

VENDOR APPROVE			
Issued/Checked/Approved			
DATE: July 21, 2023			

CUSTOMER APPROVE	
DATE:	

7/21/2023

MULTILAYER CERAMIC CHIP CAPACITORS ST SERIES

MAIN FEATURE

Soft termination series MLCC is designed and with a polymer layer within end terminations of product, which can absorb mechanical stress caused by PCB handling in SMT line and reduce the mechanical impact for product. It will offer more robust and reliable performance in applications. ST series MLCC is made by X7R dielectric and which provides product with high electrical precision, stability and reliability. Besides, ST series MLCC is tighten controlling in quality in line to assure quality performance in automotive applications. The ST series is AEC-Q200 compliant.

MAIN FEATURE

- RoHS III Compliant • MLCC's termination are with a soft & flexible polymer layer to withstand high bending stress in SMT line • High reliability: AEC-Q200.

APPLICATION

- Automotive, power supply and related industries. • The other mechanical stress concerned products or the set having a high probability • Prevention of ceramic body cracks by board bending.

RFQ
Request For Quotation

PART CODE GUIDE

Code	Name	Key Specification Option
ST	Product Code	SH is for Soft termination MLCC for Automotive Qualified to AEC-Q200
05	Size	0603 (1608): L1.60*W0.80mm; 0805 (2012): L2.00*W1.25mm; 1206 (3216:) L3.20*W1.60mm; 1210 (3225): L3.20*W2.50mm;
B	Dielectric	B: X7R;
473	Capacitance	Two significant digits followed by number of Zero, The 3rd digit signifies the multiplying factor, and letter R is decimal point. 0R5: 0.5pF; 8R2: 8.2pF; 473: 0.047μF; 100: 10pF
K	Tolerance	B=±0.1pF; C=±0.25pF; D=±0.5pF; F=±1%; G=±2%; J=±5%; K=±10%; M=±20%; Z=-20/+80%
500	Rated Voltage	Two significant digits followed by No. of zeros. "R" is in place of decimal point. 6R3=6.3 VDC; 100=10 VDC; 160=16 VDC; 250=25 VDC; 500=50 VDC; 101 =100 VDC; 201=200 VDC; 251=250 VDC; 501=500 VDC; 631=630 VDC;
D	Thickness	D: 1.25 ± 0.10mm, See Table 1
C	Package	K: 0.5 Kpcs/Reel; A: 1Kpcs/Reel; B: 2Kpcs/Reel; C: 3Kpcs/Reel; D: 4Kpcs/Reel; E: 15Kpcs/Reel; I: 10Kpcs/Reel; J: 2.5Kpcs/Reel; F: others
	Internal Control	Internal Code: Letter + Number; Blank: N/A;

MULTILAYER CERAMIC CHIP CAPACITORS ST SERIES

DIMENSION (Unit: mm)

Image for reference

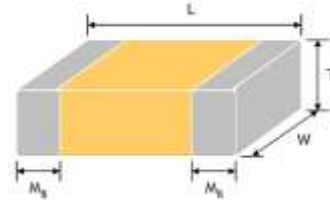

Table 1

Size Code	L	W	T (Symbol)	Remark	M B
0603 (1608)	1.60±0.20	0.80±0.10	0.80±0.07 (S)		0.40±0.15
	1.60±0.30	0.80±0.30	0.80±0.30 (X)		
0805 (2012)	2.00±0.20	1.25±0.10	1.25 ± 0.10 (D)	#	0.50 ± 0.20
1210 (3225)	3.20±0.60	2.50±0.50	2.50 ± 0.50 (M)	#	0.75 ± 0.25

Reflow soldering only is recommended.

GENERAL ELECTRONICAL CHARACTERISTICS

Table 2

Dielectric	X7R
Size	0603, 0805, 1210
Capacitance range*	1000pF to 2.2µF
Capacitance Tolerance**	J (±5%), K (±10%), M (± 20%)
Rated Voltage	10V, 16V, 25V, 50V, 100V
Operating Temperature	-55 ~+125°C
Capacitance Characteristic	± 15%
Termination	Ni/Sn (lead-free termination)

Note:

- 1) * Measured at the condition of 30~70% related humidity.
- 2) Measured at 1.0±0.2Vrms, 30~70% related humidity, 25° C ambient temperature for X7R.
- 3) ** Preconditioning for Class II MLCC: Perform a heat treatment at 150±10°C for 1 hour and then leave in ambient condition for 24±2 hours before measurement.

MULTILAYER CERAMIC CHIP CAPACITORS ST SERIES

CAPACITANCE RANGE – X7R DIELECTRIC 0603, 0805, 1210 SIZES

Table 3

Size	0402				0603				1210
VDC (V)	10	16	25	50	10	16	25	50	100
1,000pF (102)	S	S	S	S	D	D	D	D	
1,200pF (122)	S	S	S	S	D	D	D	D	
1,500pF (152)	S	S	S	S	D	D	D	D	
1,800pF (182)	S	S	S	S	D	D	D	D	
2,200pF (222)	S	S	S	S	D	D	D	D	
2,700pF (272)	S	S	S	S	D	D	D	D	
3,300pF (332)	S	S	S	S	D	D	D	D	
3,900pF (392)	S	S	S	S	D	D	D	D	
4,700pF (472)	S	S	S	S	D	D	D	D	
5,600pF (562)	S	S	S	S	D	D	D	D	
6,800pF (682)	S	S	S	S	D	D	D	D	
8,200pF (822)	S	S	S	S	D	D	D	D	
0.010μF (103)	S	S	S	S	D	D	D	D	
0.012μF (123)	S	S	S	S	D	D	D	D	
0.015μF (153)	S	S	S	S	D	D	D	D	
0.018μF (183)	S	S	S	S	D	D	D	D	
0.022μF (223)	S	S	S	S	D	D	D	D	
0.027μF (273)	S	S	S	S	D	D	D	D	
0.033μF (333)	S	S	S	X	D	D	D	D	
0.039μF (393)	S	S	S	X	D	D	D	D	
0.047μF (473)	S	S	S	X	D	D	D	D	
0.056μF (563)	S	S	S	X	D	D	D	D	
0.068μF (683)	S	S	S	X	D	D	D	D	
0.082μF (823)	S	S	S	X	D	D	D	D	
0.10μF (104)	S	S	S	X	D	D	D	D	
0.12μF (124)	X	X	X						
0.15μF (154)	X	X	X						
0.18μF (184)	X	X	X						
0.22μF (224)	X	X	X						
2.2μF (225)									M

MULTILAYER CERAMIC CHIP CAPACITORS ST SERIES
Resistance to Solvents, Mechanical Shock, Vibration, Resistance to Soldering Heat, ESD, Electrical Characterization, Terminal Strength– Requirement -X7R
Table 4

Rated vol.	D.F. ≤	Exception of D.F. ≤	
≥100V	≤ 2.5%	≤ 3%	1206 ≥ 0.47μF
		≤ 5%	0603 ≥ 0.068μF; 0805 > 0.1μF; 1206 ≥ 1μF; 1210 ≥ 2.2μF;
		≤ 10%	0805 > 0.22μF; 1210 ≥ 3.3μF
50V	≤ 2.5%	≤ 3%	0201(50V); 0603 ≥ 0.047μF; 0805 ≥ 0.18μF; 1206 ≥ 0.47μF
		≤ 5%	0201 ≥ 0.01μF; 1210 ≥ 3.3μF
		≤ 10%	0402 ≥ 0.012μF; 0603 > 0.1μF; 0805 > 0.47μF; 1206 ≥ 2.2μF; 1210 ≥ 10μF
35V	≤ 3.5%	≤ 10%	0603 ≥ 1μF; 0805 ≥ 2.2μF; 1206 ≥ 2.2μF; 1210 ≥ 10μF
25V	≤ 3.5%	≤ 5%	0201 ≥ 0.01μF; 0805 ≥ 1μF; 1210 ≥ 10μF
		≤ 7%	0603 ≥ 0.33μF
		≤ 10%	0201 ≥ 0.1μF; 0402 ≥ 0.056μF; 0603 ≥ 0.47μF; 0805 ≥ 2.2μF; 1206 ≥ 4.7μF; 1210 ≥ 22μF
		≤ 12.5%	0402 ≥ 0.47μF
16V	≤ 3.5%	≤ 5%	0201 ≥ 0.01μF; 0402 ≥ 0.033μF; 0603 ≥ 0.15μF; 0805 ≥ 0.68μF; 1206 ≥ 2.2μF; 1210 ≥ 4.7μF
		≤ 10%	0201 ≥ 0.022μF; 0402 ≥ 0.22μF; 0603 > 0.47μF; 0805 ≥ 2.2μF; 1206 ≥ 4.7μF; 1210 ≥ 22μF
10V	≤ 5.0%	≤ 10%	0201 ≥ 0.012μF; 0402 ≥ 0.22μF; 0603 ≥ 0.33μF; 0805 ≥ 2.2μF; 1206 ≥ 2.2μF; 1210 ≥ 22μF
		≤ 15%	0201 ≥ 0.1μF; 0402 ≥ 1μF
6.3V	≤ 10%	≤ 15%	0201 ≥ 0.1μF; 0402 ≥ 1μF; 0603 ≥ 10μF; 0805 ≥ 4.7μF; 1206 ≥ 47μF; 1210 ≥ 100μF
		≤ 20%	0402 ≥ 2.2μF
4V	≤ 15%	-	-

MULTILAYER CERAMIC CHIP CAPACITORS ST SERIES
High Temperature Exposure, Temperature Cycling, Moisture Resistance, Biased Humidity, Operational Life, Thermal Shock- Requirement-X7R:
Table 5

Rated vol.	D.F. ≤	Exception of D.F. ≤	
≥100V	≤ 3%	≤ 6%	1206 ≥ 0.47μF
		≤ 7.5%	0603 ≥ 0.068μF; 0805 > 0.1μF; 1206 ≥ 1μF; 1210 ≥ 2.2μF;
		≤ 20%	0805 > 0.22μF; 1210 ≥ 3.3μF
50V	≤ 3%	≤ 6%	0201(50V); 0603 ≥ 0.047μF; 0805 ≥ 0.18μF; 1206 ≥ 0.47μF
		≤ 10%	0201 ≥ 0.01μF; 1210 ≥ 3.3μF
		≤ 20%	0402 ≥ 0.012μF; 0603 > 0.1μF; 0805/X7R > 0.47μF; 1206 ≥ 2.2μF; 1210 ≥ 10μF;
35V	≤ 5%	≤ 20%	0603 ≥ 1μF; 0805 ≥ 2.2μF; 1206 ≥ 2.2μF; 1210 ≥ 10μF
25V	≤ 5%	≤ 10%	0201 ≥ 0.01μF; 0805 ≥ 1μF; 1210 ≥ 10μF
		≤ 14%	0603 ≥ 0.33μF
		≤ 15%	0201 ≥ 0.1μF; 0402 ≥ 0.056μF; 0603 ≥ 0.47μF; 0805 ≥ 2.2μF; 1206 ≥ 4.7μF; 1210 ≥ 22μF
		≤ 20%	0402 ≥ 0.47μF;
16V	≤ 5%	≤ 10%	0603 ≥ 0.15μF; 0805 ≥ 0.68μF; 1206 ≥ 2.2μF; 1210 ≥ 4.7μF
		≤ 15%	0201 ≥ 0.022μF; 0402 ≥ 0.033μF; 0603 > 0.47μF; 0805 ≥ 2.2μF; 1206 ≥ 4.7μF; 1210 ≥ 22μF
10V	≤ 7.5%	≤ 15%	0201 ≥ 0.012μF; 0402 ≥ 0.22μF; 0603 ≥ 0.33μF; 0805 ≥ 2.2μF; 1206 ≥ 2.2μF; 1210 ≥ 22μF
		≤ 20%	0201 ≥ 0.1μF; 0402 ≥ 1μF
6.3V	≤ 15%	≤ 30%	0201 ≥ 0.1μF; 0402 ≥ 1μF; 0603 ≥ 10μF; 0805 ≥ 4.7μF; 1206 ≥ 47μF; 1210 ≥ 100μF
4V	≤ 20%	-	-

MULTILAYER CERAMIC CHIP CAPACITORS ST SERIES
Resistance to Solvents, Mechanical Shock, Vibration, Resistance to Soldering Heat, ESD, Electrical Characterization – Requirement - Class II (X7R)
Table 6

Rated Voltage	IR
100V: All X7R	10GΩ or $RxC \geq 100 \Omega\text{-F}$ whichever is smaller
50V: 0402 $\geq 0.01\mu\text{F}$; 0603 $\geq 1\mu\text{F}$; 0805 $\geq 1\mu\text{F}$; 1206 $\geq 4.7\mu\text{F}$; 1210 $\geq 4.7\mu\text{F}$	
35V: 0805 $\geq 2.2\mu\text{F}$; 1206 $\geq 2.2\mu\text{F}$; 1210 $\geq 10\mu\text{F}$	
25V: 0402 $\geq 1\mu\text{F}$; 0603 $\geq 2.2\mu\text{F}$; 0805 $\geq 2.2\mu\text{F}$; 1206 $\geq 10\mu\text{F}$; 1210 $\geq 10\mu\text{F}$	
16V: 0201 $\geq 0.1\mu\text{F}$; 0402 $\geq 0.22\mu\text{F}$; 0603 $\geq 1\mu\text{F}$; 0805 $\geq 2.2\mu\text{F}$; 1206 $\geq 10\mu\text{F}$; 1210 $\geq 47\mu\text{F}$	
10V: 0201 $\geq 47\text{nF}$; 0402 $\geq 0.47\mu\text{F}$; 0603 $\geq 0.47\mu\text{F}$; 0805 $\geq 2.2\mu\text{F}$; 1206 $\geq 4.7\mu\text{F}$; 1210 $\geq 47\mu\text{F}$	
6.3V ; 4V	
Rated Voltage	$RxC \geq 50 \Omega\text{-F.}$
100V: 1210 $\geq 3.3\mu\text{F}$	
50V: 0402 $\geq 0.1\mu\text{F}$; 0603 $\geq 2.2\mu\text{F}$; 0805 $\geq 10\mu\text{F}$; 1206 $\geq 10\mu\text{F}$	
35V: 0603 $\geq 1\mu\text{F}$	
25V: 0201 $\geq 0.1\mu\text{F}$; 0402 $\geq 0.22\mu\text{F}$; 0603 $\geq 10\mu\text{F}$; 0805 $\geq 10\mu\text{F}$; 1206 $\geq 22\mu\text{F}$	
16V: 0201 $\geq 0.22\mu\text{F}$; 0402 $\geq 1\mu\text{F}$; 0603 $\geq 10\mu\text{F}$	
10V: 0201 $\geq 0.1\mu\text{F}$; 0402 $\geq 1\mu\text{F}$; 0603 $\geq 10\mu\text{F}$; 0805 $\geq 47\mu\text{F}$	
6.3V: 0201 $\geq 0.1\mu\text{F}$; 0402 $\geq 1\mu\text{F}$; 0603 $\geq 4.7\mu\text{F}$; 0805 $\geq 47\mu\text{F}$; 1206 $\geq 10\mu\text{F}$;	
4V: 0603 $\geq 22\mu\text{F}$; 0805 $\geq 47\mu\text{F}$; 1206 $\geq 100\mu\text{F}$	

High Temperature Exposure, Temperature Cycling, Moisture Resistance, Operational Life , Thermal Shock– Requirement - Class II (X7R)
Table 7

Measurement Voltage	IR
100V: All X7R	1GΩ or $RxC \geq 10\Omega\text{-F}$ whichever is smaller
50V: 0402 $\geq 0.01\mu\text{F}$; 0603 $\geq 1\mu\text{F}$; 0805 $\geq 1\mu\text{F}$; 1206 $\geq 4.7\mu\text{F}$; 1210 $\geq 4.7\mu\text{F}$	
35V: 0603 $\geq 1\mu\text{F}$; 0805 $\geq 2.2\mu\text{F}$; 1206 $\geq 2.2\mu\text{F}$; 1210 $\geq 10\mu\text{F}$	
25V: 0201 $\geq 0.1\mu\text{F}$; 0402 $\geq 0.22\mu\text{F}$; 0603 $\geq 2.2\mu\text{F}$; 0805 $\geq 2.2\mu\text{F}$; 1206 $\geq 10\mu\text{F}$; 1210 $\geq 10\mu\text{F}$	
16V: 0201 $\geq 0.1\mu\text{F}$; 0402 $\geq 0.22\mu\text{F}$; 0603 $\geq 1\mu\text{F}$; 0805 $\geq 2.2\mu\text{F}$; 1206 $\geq 10\mu\text{F}$; 1210 $\geq 47\mu\text{F}$	
10V: 0201 $\geq 47\text{nF}$; 0402 $\geq 0.47\mu\text{F}$; 0603 $\geq 0.47\mu\text{F}$; 0805 $\geq 2.2\mu\text{F}$; 1206 $\geq 4.7\mu\text{F}$; 1210 $\geq 47\mu\text{F}$	
6.3V; 4V	

MULTILAYER CERAMIC CHIP CAPACITORS ST SERIES

Biased Humidity – Requirement - Class II (X7R)

Table 8

Measurement Voltage	IR
100V: All X7R	500MΩ or $RxC \geq 5 \Omega\text{-F}$ whichever is smaller.
50V: 0402>0.01μF; 0603≥1μF; 0805≥1μF; 1206≥4.7μF; 1210≥4.7μF	
35V:0603≥1μF;0805≥2.2μF; 1206≥2.2μF;1210≥10μF	
25V: 0201≥0.1uF; 0402≥0.22μF; 0603≥2.2μF; 0805≥2.2μF; 1206≥10μF; 1210≥10μF	
16V: 0201≥0.1uF; 0402≥0.22μF; 0603≥1μF ;0805≥2.2μF; 1206≥10μF; 1210≥47μF	
10V: 0201≥47nF; 0402≥0.47μF; 0603≥0.47μF; 0805≥2.2μF; 1206≥4.7μF; 1210≥47μF	
6.3V; 4V	

Biased Humidity– Requirement - Class II (X7R) for 1.3~1.5Vdc

Table 9

Measurement Voltage	IR
100V: All X7R	1GΩ or $RxC \geq 10\Omega\text{-F}$ whichever is smaller
50V: 0402>0.01μF; 0603≥1μF; 0805≥1μF; 1206≥4.7μF; 1210≥4.7μF	
35V:0603≥1μF;0805≥2.2μF; 1206≥2.2μF;1210≥10μF	
25V: 0201≥0.1uF; 0402≥0.22μF; 0603≥2.2μF; 0805≥2.2μF; 1206≥10μF; 1210≥10μF	
16V: 0201≥0.1uF; 0402≥0.22μF; 0603≥1μF ;0805≥2.2μF; 1206≥10μF; 1210≥47μF	
10V: 0201≥47nF; 0402≥0.47μF; 0603≥0.47μF; 0805≥2.2μF; 1206≥4.7μF; 1210≥47μF	
6.3V; 4V	

MULTILAYER CERAMIC CHIP CAPACITORS ST SERIES

RELIABILITY TEST CONDITIONS AND REQUIREMENTS

Item	AEC-Q200 Test Condition	Requirements
<p>Pre-and Post-Stress Electrical Test</p>	<p>-</p>	
<p>High Temperature Exposure (Storage) MIL-STD-202 Method 108</p>	<p>* Test temp.: $150 \pm 3^\circ \text{C}$ * Unpowered. *Test time: 1000+24/-0 hrs. * Measurement to be made after keeping at room temp. for 24 ± 2 hrs.</p>	<p>*No remarkable damage. *Cap change: NP0: within $\pm 2.5\%$ or $\pm 0.25\text{pF}$ whichever is larger. X7R: within $\pm 10.00\%$. * Q/D.F. value: NP0: $\text{Cap} \geq 30\text{pF}$, $\text{Q} \geq 1000$; $\text{Cap} < 30\text{pF}$, $\text{Q} \geq 400+20\text{C}$. X7R, See <Table 5> * I.R.: $\geq 10\text{G}\Omega$ or $\text{RxC} \geq 500\Omega\text{-F}$ whichever is smaller. Class II (X7R) , See <Table 7></p>
<p>Temperature : Cycling JESD22 Method JA-104</p>	<p>*Conduct 1000 cycles according to the temperatures and time. Step 1: $-55^\circ \text{C} +0/-3^\circ \text{C}$ @ 5 ± 1 min. Step 2: $+125^\circ \text{C} +3/-0^\circ \text{C}$ @ 5 ± 1 min. Before initial measurement (X7R only): Perform $150+0/-10^\circ \text{C}$ for 1 hr and then set for 24 ± 2 hrs at room temp. *Measurement to be made after keeping at room temp. for 24 ± 2 hrs.</p>	<p>* No remarkable damage. *Cap change: NP0: within $\pm 2.5\%$ or $\pm 0.25\text{pF}$ whichever is larger. X7R: within $\pm 10.00\%$. *Q/D.F. value: NP0: $\text{Cap} \geq 30\text{pF}$, $\text{Q} \geq 1000$; $\text{Cap} < 30\text{pF}$, $\text{Q} \geq 400+20\text{C}$ X7R, See <Table 5> * I.R.: $\geq 10\text{G}\Omega$ or $\text{RxC} \geq 500\Omega\text{-F}$ whichever is smaller. Class II (X7R) , See <Table 7></p>

MULTILAYER CERAMIC CHIP CAPACITORS ST SERIES
RELIABILITY TEST CONDITIONS AND REQUIREMENTS

Item	AEC-Q200 Test Condition	Requirements
Destructive Physical Analysis EIA-469	Per EIA-469	No defects or abnormalities
Moisture Resistance MIL-STD-202 Method 106	Test temp.: 25~65° C Humidity: 80~100% RH Test time: 10 cycles, t=24hrs/cycle. Measurement to be made after keeping at room temp. for 24±2 hrs.	* No remarkable damage. * Cap change: NPO: within ±3.0% or ±0.30pF whichever is larger. X7R: within ±12.5%. *Q/D.F. value: NPO: More than 30pF Q≥350 ; 10pF≤C≤30pF, Q≥275+2.5C Less than 10pF Q≥200+10. X7R, See <Table 5> * I.R.: ≥10GΩ or RxC≥500Ω-F whichever is smaller. Class II (X7R) , See <Table 7>
Biased Humidity MIL-STD-202 Method 103	Test temp.: 85±3° C Humidity: 85%RH Test time: 1000+24/-0 hrs. To apply voltage: rated voltage and 1.3~1.5Vdc. (add 100k ohm resistor) Before initial measurement (Class II only) : To apply test voltage for 1hr at test temp. and then set for 24±2 hrs at room temp. Measurement to be made after keeping at room temp. for 24±2hrs.	* No remarkable damage. * Cap change: NPO: within ±3.0% or ±0.30pF whichever is larger. X7R: within ±12.5%. *Q/D.F. value: NPO: C≥30pF Q≥200 ; C≤30pF, Q≥100+10/3C X7R, See <Table 5> * I.R.: ≥10GΩ or RxC≥500Ω-F whichever is smaller. Class II (X7R) , See <Table 8> Class II (X7R) for 1.3~1.5Vdc See <Table 9>

MULTILAYER CERAMIC CHIP CAPACITORS ST SERIES

RELIABILITY TEST CONDITIONS AND REQUIREMENTS

Item	AEC-Q200 Test Condition	Requirements
Operational Life MIL-STD-202 Method 108	Test temp.: $125 \pm 3^\circ \text{C}$ To apply voltage: full rated voltage. * Test time: 1000+24/-0 hrs. Before initial measurement (X7R only): Apply rated voltage for 1 hr at 125°C . Remove and let set for 24 ± 2 hrs at room temp. Measurement to be made after keeping at room temp. for 24 ± 2 hrs.	* No remarkable damage. * Cap change: NPO: within $\pm 3.0\%$ or $\pm 0.30\text{pF}$ whichever is larger. X7R: within $\pm 12.5\%$. *Q/D.F. value: NPO: More than 30pF $Q \geq 350$; 10pF $\leq C \leq 30\text{pF}$, $Q \geq 275 + 2.5C$ Less than 10pF $Q \geq 200 + 10$. X7R, See <Table 5> * I.R.: $\geq 1\text{G}\Omega$ or $RxC \geq 50\Omega\text{-F}$ whichever is smaller. Class II (X7R) , See <Table 7>
External Visual MIL-STD-883 Method 2009	Visual inspection	No remarkable defect.
Physical Dimension JESD22 Method JB-100	Using by calipers	Within the specified dimensions
Resistance to Solvents MIL-STD-202 Method 215	* Temperature: $25 \pm 5^\circ \text{C}$ * Time: 3+0.5/-0 min. * Solvent: Iso-propyl alcohol.	* No remarkable damage. * Cap.: within the specified tolerance. * Q/D.F. value: NPO: Cap $\geq 30\text{pF}$, $Q \geq 1000$; Cap $\geq 400 + 20C$. X7R, See <Table 4> * I.R.: $\geq 10\text{G}\Omega$ or $RxC \geq 500\Omega\text{-F}$ whichever is smaller. Class II (X7R) , See <Table 6>

MULTILAYER CERAMIC CHIP CAPACITORS ST SERIES

RELIABILITY TEST CONDITIONS AND REQUIREMENTS

Item	AEC-Q200 Test Condition	Requirements
Mechanical Shock MIL-STD-202 Method 213	Peak value: 1500g's. Wave: 1/2 sine. Velocity: 15.4 ft/sec Three shocks in each direction should be applied along 3 mutually perpendicular axes of the test specimen (18 shocks)	* No remarkable damage. * Cap change: within the specified tolerance. *Q/D.F. value: NPO: Cap \geq 30pF, Q \geq 1000 ; Cap $<$ 30pF, Q \geq 400+20C X7R, See <Table 4> * I.R.: \geq 10G Ω or Rx $C\geq$ 500 Ω -F whichever is smaller. Class II (X7R) , See <Table 6>
Vibration MIL-STD-202 Method 204	*Vibration frequency:10~2000Hz/min. (5g's for 20 min) *Total amplitude: 1.5mm *12 cycles each of 3 orientations (36 times)	* No remarkable damage. * Cap change: within the specified tolerance. *Q/D.F. value: NPO: Cap \geq 30pF, Q \geq 1000 ; Cap $<$ 30pF, Q \geq 400+20C X7R, See <Table 4> * I.R.: \geq 10G Ω or Rx $C\geq$ 500 Ω -F whichever is smaller. Class II (X7R) , See <Table 6>
Resistance to Soldering Heat MIL-STD-202 Method 210	*Solder temperature: 270 \pm 5 $^{\circ}$ C *Dipping time: 10 \pm 1 sec *Before initial measurement (X7R only): Perform 150+0/-10 $^{\circ}$ C for 1 hr and then set for 24 \pm 2 hrs at room temp. * Measurement to be made after keeping X7R: at room temp. for 24 \pm 2 hrs.	* No remarkable damage. * Cap change: NPO: within \pm 2.5% or 0.25pF whichever is larger X7R: within \pm 7.5% *Q/D.F. value: NPO: Cap \geq 30pF, Q \geq 1000 ; Cap $<$ 30pF, Q \geq 400+20C X7R, See <Table 4> * I.R.: \geq 10G Ω or Rx $C\geq$ 500 Ω -F whichever is smaller. Class II (X7R) , See <Table 6>

MULTILAYER CERAMIC CHIP CAPACITORS ST SERIES

RELIABILITY TEST CONDITIONS AND REQUIREMENTS

Item	Test Condition	Requirements
<p>Thermal Shock MIL-STD-202 Method 107</p>	<p>*Conduct 300 cycles according to the temperatures and time. Step 1: -55° C +0/-3° C @ 15±3 min. Step 2: +125° C +3/-0° C @ 15±3 min. *Max.transfer time:20 sec *Before initial measurement (X7R only): Perform 150+0/-10° C for 1 hr and then set for 24±2 hrs at room temp. *Measurement to be made after keeping at room temp. for 24±2 hrs</p>	<p>* No remarkable damage. * Cap change: NPO: within ±2.5% or 0.25pF whichever is larger X7R: within ±10.0% *Q/D.F. value: NPO: Cap≥30pF, Q≥1000 ; Cap<30pF, Q≥400+20C X7R, See <Table 5> * I.R.: ≥10GΩ or RxC≥500Ω-F whichever is smaller. Class II (X7R) , See <Table 7></p>
<p>ESD AEC-Q200-002</p>	<p>Per AEC-Q200-002</p>	<p>* No remarkable damage. * Cap change: within the specified tolerance. *Q/D.F. value: NPO: Cap≥30pF, Q≥1000 ; Cap<30pF, Q≥400+20C X7R, See <Table 4> * I.R.: ≥10GΩ or RxC≥500Ω-F whichever is smaller. Class II (X7R) , See <Table 6></p>
<p>Solderability J-STD-002 JESD22-B102E</p>	<p>*Condition A Un-mounted chips 4hrs / 155° C *dry then completely immersed for 5±0.5 sec in solder bath at 235±5° C. *Condition B Un-mounted chips steam 8 hrs then completely immersed for 10±1sec in solder bath at 215+5/-0° C. *Condition C Un-mounted chips steam 8 hrs then completely immersed for 10±1 sec. in solder bath at 260+0/-5° C.</p>	<p>All terminations shall exhibit a continuous solder coating free from defects from a minimum of 95% of the critical surface area of any individual termination.</p>

MULTILAYER CERAMIC CHIP CAPACITORS ST SERIES

RELIABILITY TEST CONDITIONS AND REQUIREMENTS

Item	Test Condition	Requirements
<p>Electrical Characterization</p>	<p>*Capacitance</p> <p>*Q/ D.F. (Dissipation Factor)</p> <p>*Test temp.: Room Temperature.</p> <p>Class I: (NPO)</p> <p>Cap≤1000pF 1.0 ± 0.2Vrms, 1MHz ± 10%</p> <p>Cap>1000pF 1.0 ± 0.2Vrms, 1KHz ± 10%</p> <p>Class II: (X7R)</p> <p>Cap ≤10μF, 1.0 ± 0.2Vrms, 1KHz ± 10%</p> <p>Cap > 10μF, 0.5 ± 0.2Vrms, 120Hz ± 20%</p> <p>*Dielectric strength To apply voltage:</p> <p>≤100 ≥2.5 times VDC</p> <p>200V~300V ≥2 times VDC</p> <p>400V~450V ≥1.2 times VDC</p> <p>500V~999V ≥1.5 times VDC</p> <p>1000V~3000V ≥1.2 times VDC ,</p> <p>duration 1~5 sec,</p> <p>charge and discharge current less than 50mA.</p> <p>* Temperature Coefficient (with no electrical load)</p> <p>Operation temperature: -55~125° C at 25° C</p>	<p>* Cap change: within the specified tolerance.</p> <p>*Q/D.F. value:</p> <p>NPO: Cap≥30pF, Q≥1000 ;</p> <p>Cap<30pF, Q≥400+20C</p> <p>X7R, See <Table 4></p> <p>* I.R.: ≥10GΩ or RxC≥500Ω-F whichever is smaller.</p> <p>Class II (X7R) , See <Table 6></p> <p>*Dielectric strength</p> <p>No evidence of damage or flash over during test.</p> <p>*Temperature Coefficient</p> <p>Capacitance Change:</p> <p>NPO: Within ± 30ppm/° C</p> <p>X7R: Within ± 15%</p>
<p>Board Flex AEC-Q200-005</p>	<p>*The middle part of substrate shall be pressurized by means of the pressurizing rod at a rate of about 1 mm per second until the deflection becomes 5 mm and then the pressure shall be maintained for 60 ± 1 sec.</p> <p>* Measurement to be made after keeping at room temp. for 24 ± 2 hrs.</p>	<p>* No remarkable damage.</p> <p>*Cap change: NPO: within ± 5.0% or ± 0.5pF whichever is larger.</p> <p>X7R: within ± 12.5%. (This capacitance change means the change of capacitance under specified flexure of substrate from the capacitance measured before the test.)</p>

MULTILAYER CERAMIC CHIP CAPACITORS ST SERIES

RELIABILITY TEST CONDITIONS AND REQUIREMENTS

Item	Test Condition	Requirements
Terminal Strength AEC-Q200-006	*Pressurizing force: 2N (0201 & 0402), 10N(0603), 18N(\geq 0805) * Test time: 60 ± 1 sec. $35V \leq 3.5\% \leq 10\%$	*No remarkable damage or removal of the terminations. * Capacitance within the specified tolerance * Q/D.F. value: NPO: $Cap \geq 30pF$, $Q \geq 1000$; $Cap < 30pF$, $Q \geq 400+20C$ X7R, See <Table 4>
Beam Load Test AEC-Q200-003	* Break strength test * Beam speed: 2.5 ± 0.25 mm/se	The chip endure following force * Chip length $\leq 2.5mm$: Thickness $> 0.5mm$ (20N), $\leq 0.5mm$ (8N) * Chip length $\geq 3.2mm$: Thickness $\geq 1.25mm$ (54.5N), $< 1.25mm$ (15N)

MULTILAYER CERAMIC CHIP CAPACITORS ST SERIES

RECOMMENDED PROFILE CONDITIONS

The lead-free termination MLCCs are not only to be used on SMT against lead-free solder paste, but also suitable against lead-containing solder paste.

If the optimized solder joint is requested, increasing soldering time, temperature and concentration of N2 within oven are recommended.

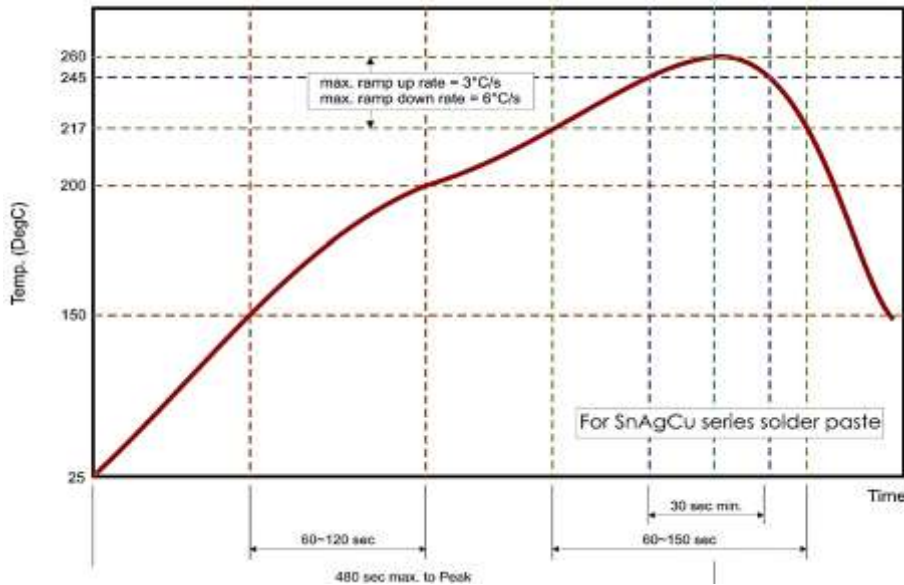

Reflow Soldering Profile For SMT Process with SnAgCu series Solder Paste

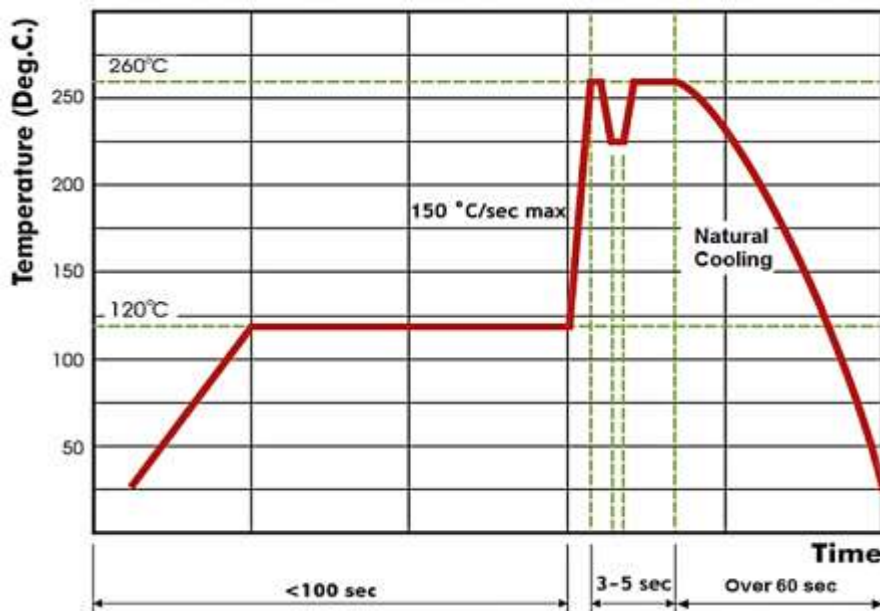

Wave Soldering Profile For SMT Process with SnAgCu series Solder Paste

MULTILAYER CERAMIC CHIP CAPACITORS ST SERIES
PACKAGING STYLE AND QUANTITY

Size	Thickness (Symbol)		Paper Tape		Plastic Tape	
			7" Reel	13" Reel	7" Reel	13" Reel
0402 (1005)	0.50±0.20	E	10,000			
0603 (1608)	0.80±0.07	S	4,000	15,000		
	0.80±0.30	X	4,000	15,000		
0805 (2012)	0.60±0.10	A	4,000	15,000		
	0.85±0.10	B	4,000	15,000		
	1.25±0.10	D			3,000	10,000
	1.25±0.30	I			3,000	10,000
1206 (3216)	0.85±0.10	B	4,000	15,000		
	0.95±0.10	C			3,000	10,000
	1.15±0.15	J			3,000	10,000
	1.25±0.10	D			3,000	10,000
	1.60±0.20	G			2,000	10,000
	1.60±0.50	P			2,000	9,000
1210 (3225)	0.95±0.10	C			3,000	10,000
	1.25±0.10	D			3,000	10,000
	1.60±0.20	G			2,000	
	2.00±0.20	K			1,000	6,000
	2.50±0.50	M			1,000	6,000

Constructions

Size Code	Name		NPO	X7R, X5R, Y5V
1	Ceramic material		CaZrO3 based	BaTiO3 based
2	Inner electrode		Ni	
3	Termination	Inner layer	Cu + Ag Polymer	
4		Middle layer	Ni	
5		Outer layer	Sn	

MULTILAYER CERAMIC CHIP CAPACITORS ST SERIES

Constructions

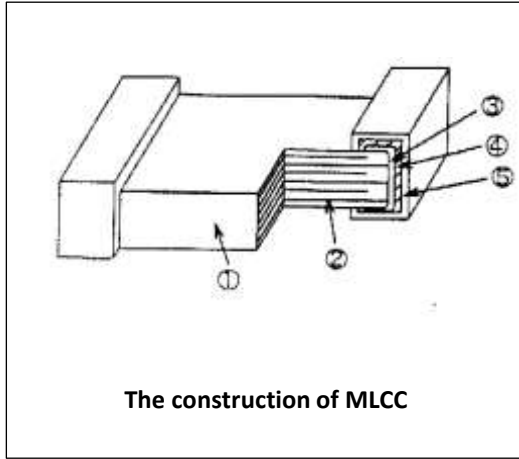

REEL DIMENSION (Unit: mm)

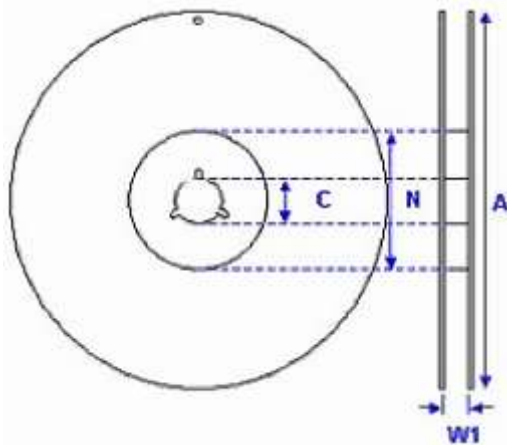

Size Code	0201, 0402, 0603, 0805, 1206, 1210		
Reel Size	7"	10"	13"
C	13.0±0.5	13.0±0.5	13.0±0.5
W 1	10.0±1.5	10.0±1.5	10.0±1.5
A	178.0±2.0	250.0±2.0	330.0±2.0
N	60.0+1.0/-0	50 min	50 min

MULTILAYER CERAMIC CHIP CAPACITORS ST SERIES

TAPE DIMENSION (Unit: mm)

Paper Tape

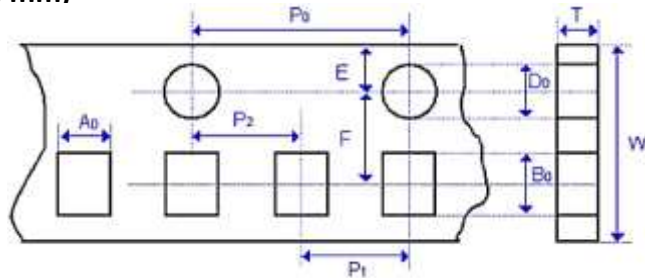

Plastic Tape

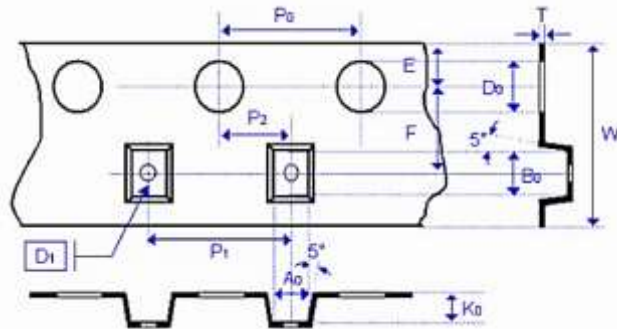

Size	0603	0805		
Thickness	S, H, X	A, H	B, T	D, I
A0	1.05 +/-0.30	1.5+/-0.20	1.5 +/--0.20	≤1.80
B0	1.80 +/-0.30	2.30 +/--0.20	2.30 +/--0.20	< 2.70
T	≤1.20	≤1.15	≤1.20	0.23 +/--0.1
K0	-	-	-	< 2.50
W	8.00 +/-0.30	8.00 +/-0.30	8.00 +/-0.30	8.00 +/-0.30
P0	4.00 +/-0.10	4.00 +/-0.10	4.00 +/-0.10	4.00 +/-0.10
10xP0	40.0 +/-0.20	40.0 +/-0.20	40.0 +/-0.20	40.0 +/-0.20
P1	4.00 +/-0.10	4.00 +/-0.10	4.00 +/-0.10	4.00 +/-0.10
P2	2.00 +/-0.05	2.00 +/-0.05	2.00 +/-0.05	2.00 +/-0.05
D0	1.50 +0.1/-0	1.50 +0.1/-0	1.50 +0.1/-0	1.50 +0.1/-0
D1	-	-	-	-
E	1.75 +/-0.10	1.75 +/-0.10	1.75 +/-0.10	1.75 +/-0.10
F	3.50 +/-0.05	3.50 +/-0.05	3.50 +/-0.05	3.50 +/-0.05

MULTILAYER CERAMIC CHIP CAPACITORS ST SERIES
TAPE DIMENSION (Unit: mm)

Size	1206			1210		
	B, T	C, J, D	G, P	T	C, D, G, K	M
Thickness						
A0	1.90 +/-0.50	< 2.00	< 2.30	< 3.05	< 3.05	< 3.20
B0	3.50 +/-0.50	< 3.70	< 4.00	< 3.80	< 3.80	< 4.00
T	≤1.20	0.23 +/-0.1	0.23 +/-0.1	0.23 +/-0.1	0.23 +/-0.1	0.23 +/-0.1
K0	-	< 2.50	< 2.50	< 1.50	< 2.50	< 3.50
W	8.00 +/-0.30	8.00 +/-0.30	8.00 +/-0.30	8.00 +/-0.30	8.00 +/-0.30	8.00 +/-0.30
P0	4.00 +/-0.10	4.00 +/-0.10	4.00 +/-0.10	4.00 +/-0.10	4.00 +/-0.10	4.00 +/-0.10
10xP0	40.0 +/-0.20	40.0 +/-0.20	40.0 +/-0.20	40.0 +/-0.20	40.0 +/-0.20	40.0 +/-0.20
P1	4.00 +/-0.10	4.00 +/-0.10	4.00 +/-0.10	4.00 +/-0.10	4.00 +/-0.10	4.00 +/-0.10
P2	2.00 +/-0.05	2.00 +/-0.05	2.00 +/-0.05	2.00 +/-0.05	2.00 +/-0.05	2.00 +/-0.05
D0	1.50 +0.1/-0	1.50 +0.1/-0	1.50 +0.1/-0	1.50 +0.1/-0	1.50 +0.1/-0	1.50 +0.1/-0
D1	-	-	-	1.00 +/-0.10	1.00 +/-0.10	1.00 +/-0.10
E	1.75 +/-0.10	1.75 +/-0.10	1.75 +/-0.10	1.75 +/-0.10	1.75 +/-0.10	1.75 +/-0.10
F	3.50 +/-0.05	3.50 +/-0.05	3.50 +/-0.05	3.50 +/-0.05	3.50 +/-0.05	3.50 +/-0.05

MULTILAYER CERAMIC CHIP CAPACITORS ST SERIES

STORAGE AND HANDLING CONDITIONS

- (1) To store products at 5 to 40° C ambient temperature and 20 to 70% related humidity conditions; MSL Level 1.
- (2) The product is recommended to be used within one year after shipment. Check solderability in case of shelf life extension is needed.

CAUTIONS

- (1) The corrosive gas reacts on the terminal electrodes of capacitors, and results in the poor solder ability. Do not store the capacitors in the ambience of corrosive gas (e.g., hydrogen sulfide, sulfur dioxide, chlorine, ammonia gas etc.)
- (2) In corrosive atmosphere, solder ability might be degraded, and silver migration might occur to cause low reliability.
- (3) Due to the dewing by rapid humidity change, or the photochemical change of the terminal electrode by direct sun light, the solder ability and electrical performance may deteriorate. Do not store capacitors under direct sunlight or dewing condition. To store products on the shelf and avoid exposure to moisture.

Caution for SOFT TERMINATION Products

Since the middle layer of the terminal electrode contains Ag (silver), when chip capacitors on printed circuit board (PCB), it should be protected by moisture proof-sealing to prevent electromigration of Ag under high temperature, high humidity and failure due to corrosive gas.

DISCLAIMER

NextGen Component, Inc. reserves the right to make changes to the product(s) and or information contained herein without notice. No liability is assumed as a result of their use or application. No rights under any patent accompany the sale of any such product(s) or information